

P4. Elizabeth put a weight and a beaker of water on a scale, as shown in the first picture.

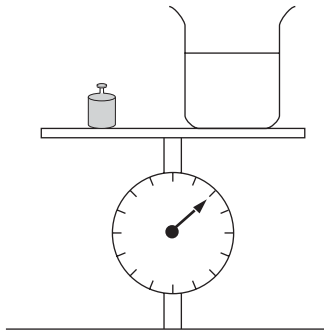

Then she moved the beaker and put the weight in it, as shown in the second picture.

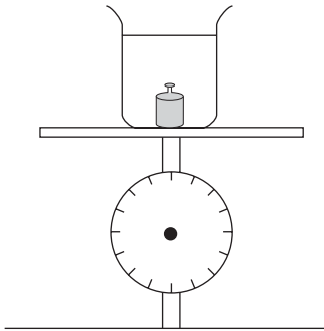

What will the scale show now? Draw an arrow on the second picture to show your answer.

Reproduced from TIMSS Population 1 Item Pool. Copyright © 1994 by IEA, The Hague

Subject	Item Key	Content Category	Performance Expectation	International Average Percent of Students Responding Correctly		International Difficulty Index
				Upper Grade	Lower Grade	
Science	Next Page	Physical Science	Theorizing, Analyzing, and Solving Problems	34%	27%	672

P-4 Coding Guide

P4. Elizabeth put a weight and a beaker of water on a scale, as shown in the first picture.

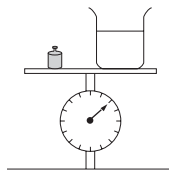

Then she moved the beaker and put the weight in it, as shown in the second picture.

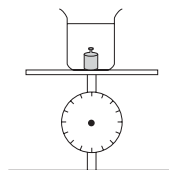

What will the scale show now? Draw an arrow on the second picture to show your answer.

Copyright © 1994 by IEA, The Hague

Code	Response
Correct Response	
10	The arrow or line is in the same position as in the first diagram or is described in words. Allow about 0.5 mm tolerance on each side.
Incorrect Response	
70	The arrow is pointing to a greater weight, that is the arrow is pointing downward somewhere between its original position and vertically down. OR the student states that it "Weighs more" or similar expression.
71	The arrow is pointing to a lesser weight than in the original picture, that is the arrow is pointing upward, between the original position and vertically up. OR the student states that it "Weighs less" or similar expression.
79	Other incorrect.
Nonresponse	
90	Crossed out/erased, illegible, or impossible to interpret.
99	BLANK